



# TAI-SAW TECHNOLOGY CO., LTD.

No. 3, Industrial 2nd Rd., Ping-Chen Industrial District,  
Taoyuan, 324, Taiwan, R.O.C.  
TEL: 886-3-4690038 FAX: 886-3-4697532  
E-mail: [tstales@mail.taisaw.com](mailto:tstales@mail.taisaw.com) Web: [www.taisaw.com](http://www.taisaw.com)

## Approval Sheet For Product Specification

Issued Date: 06/15/2006

Product Name: SMD7x5 8.000 MHz Crystal Resonator

TST Part No.: TZ0622A (Rev 1.0)

Customer Part No.: \_\_\_\_\_

Company: _____
Division: _____
Approved by : _____
Date: _____

Checked by: \_\_\_\_\_ Robert Chang

Approved by: \_\_\_\_\_ TF Yang

Date: \_\_\_\_\_ 06/15/2006



# TAI-SAW TECHNOLOGY CO., LTD.

No. 3, Industrial 2nd Rd., Ping-Chen Industrial District,  
Taoyuan, 324, Taiwan, R.O.C.

TEL: 886-3-4690038 FAX: 886-3-4697532

E-mail: [tstsales@mail.taisaw.com](mailto:tstsales@mail.taisaw.com) Web: [www.taisaw.com](http://www.taisaw.com)

## 8.000 MHz Crystal Resonator

MODEL NO.: TZ0622A

REV. NO.: 1.0

### Electrical Specifications:

RoHS Compliant  
Lead free  
Lead-free soldering

	Specification
Nominal Frequency	8.000 MHz
Mode of Vibration	Fundamental
Storage Temperature Range	-30°C to +125°C
Operating Temperature Range	-0°C to +125°C
Frequency Stability over Operating Temperature Frequency Make Tolerance @ 25°C +/- 3°C	+/-100 ppm (overall)
Max. Value of the Series Resistor	80 Ω max.
Max. Value of the Parallel Capacitor	7 pF
Drive Level	100 uW nominal
Load Capacitance-CL	16.0 pF
Aging	+/-3.0 ppm/year @25°C
Marking	Laser marking
Insulation Resistance	500M Ω min at DC 100V

Mechanical Dimensions (mm):	Marking:

# PACKING:

## 1. REEL DIMENSION (Unit: mm)

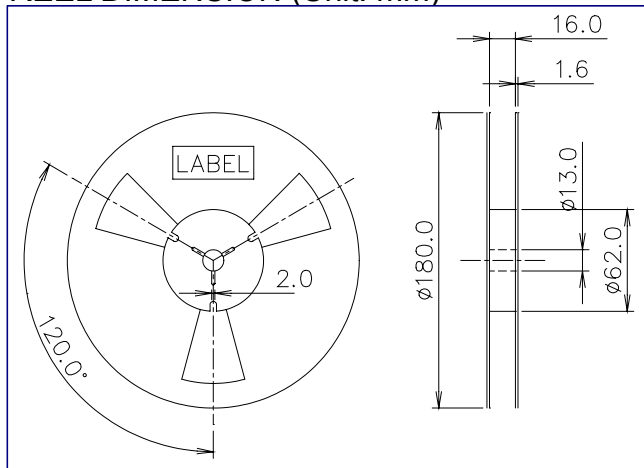

## 2. TAPE DIMENSION (Unit: mm)

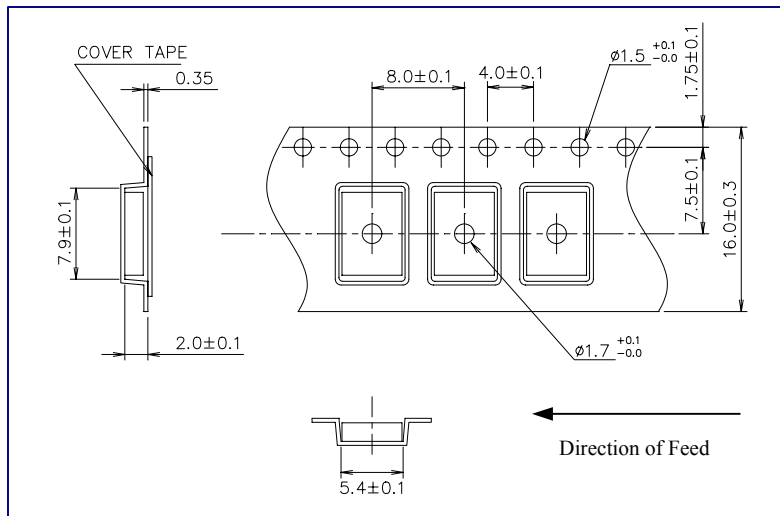

## 3. PACKING DIRECTION

The product code of marking should be close to the hole of tape.

## Product Code Table

Year	2001 2005	2002 2006	2003 2007	2004 2008
Product Code	Z	z	<u>Z</u>	<u>z</u>

## Date Code Table

WK01	WK02	WK03	WK04	WK05	WK06	WK07	WK08	WK09	WK10	WK11	WK12	WK13
A	B	C	D	E	F	G	H	I	J	K	L	M
WK14	WK15	WK16	WK17	WK18	WK19	WK20	WK21	WK22	WK23	WK24	WK25	WK26
N	O	P	Q	R	S	T	U	V	W	X	Y	Z
WK27	WK28	WK29	WK30	WK31	WK32	WK33	WK34	WK35	WK36	WK37	WK38	WK39
a	b	c	d	e	f	g	h	i	j	k	l	m
WK40	WK41	WK42	WK43	WK44	WK45	WK46	WK47	WK48	WK49	WK50	WK51	WK52
n	o	p	q	r	s	t	u	v	w	x	y	z